

DATA SHEET

**U 5.101**

# ROTARY VANE- VACUUM PUMPS

oil-lubricated

air-cooled

---

**MAKE IT BECKER.**



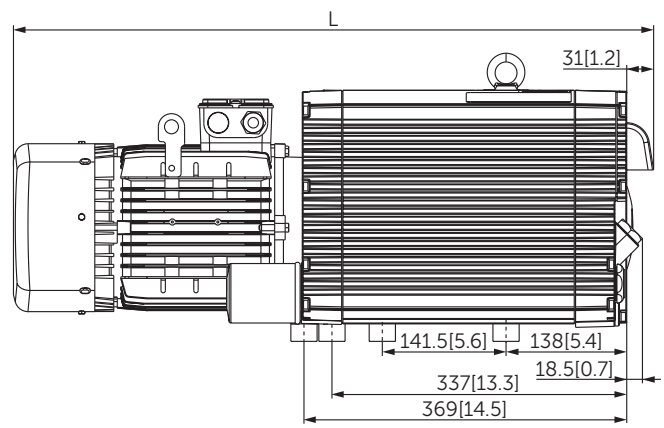
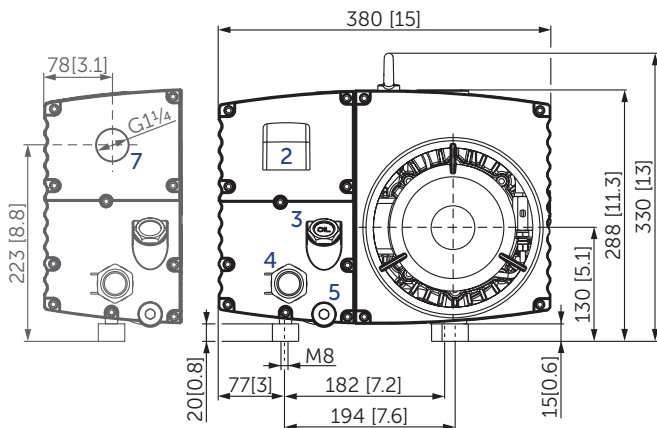

- 1 Vacuum connection (G1<sup>1</sup>/<sub>4</sub>)
- 2 Exhaust air (diverter)
- 3 Oil filler cap (G<sup>3</sup>/<sub>4</sub>)
- 4 Oil sight glas (G1)
- 5 Screw plug for oil drain (G<sup>1</sup>/<sub>2</sub>)
- 6 Rubber buffer position
- 7 optional: threaded connector for exhaust air (G1<sup>1</sup>/<sub>4</sub>)
  - incl. gas ballast valve, non-return valve, oil separator and oil filter
  - The motor illustration may vary
  - Dimensions in mm [inch]

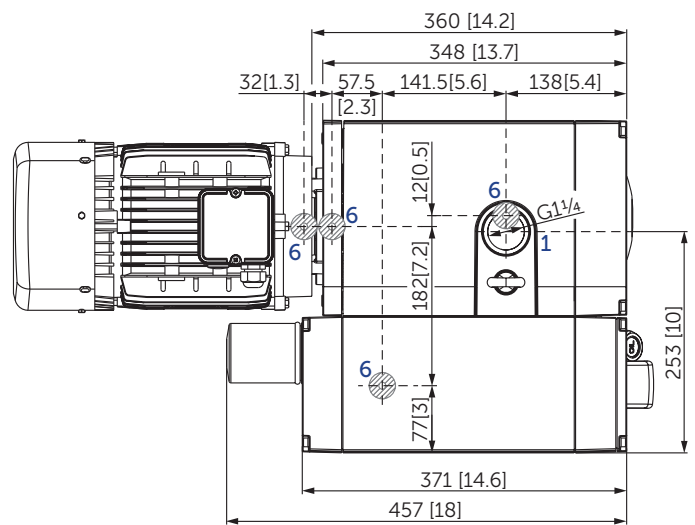

Nominal capacity		Vacuum absolute for continuous operation		Emission sound pressure level <sup>1)</sup>		Weight w/o motor	Oil <sup>2)</sup>
m <sup>3</sup> /h		mbar		dB(A)		kg	l
50 Hz	60 Hz	50 Hz	60 Hz	50 Hz	60 Hz		
100	120	<0.1 <sup>3)</sup>	-400	65	68	40,0	2

<sup>1)</sup> According to DIN EN ISO 11203, accuracy class of measurement: class 2, extended measurement uncertainty: 3 dB  
1 m [39.4 inch] distance, at medium load, both connection sides piped

<sup>2)</sup> Becker Lube M100 mineral • S100 synthetic • SL100 food

<sup>3)</sup> 0.5 mbar absolute with opened gas ballast valve

▪ Gas ballast valve: water vapour tolerance max. 7 mbar; water vapour capacity max. 0.9 l/h (at 85°C operating temperature)

3~ Motors											L		
#	50 Hz				60 Hz				Version	Weight kg	mm [inch]		
	kW	V	min <sup>-1</sup>	A	kW	V	min <sup>-1</sup>	A					
01	2.2	Δ230/Y400	IE3	1460	7.45/4.3	2.20	Y460	IE3	1766	3.8	UL(E68554) • CSA CC055B IP55 • ISO F • PTC	29.0	706 [27.8]
						2.64	Δ208		1740	9.7			
						2.64	Δ230		1752	8.7			
						2.64	Y400		1752	5.0			
						2.64	Y460		1758	4.0			
02					2.6	YY230/Y460	IE3	1765	9.3/4.6	UL(E365362) • CSA CC334B IP55 • ISO F • bimetal	37.0	741 [29.2]	
						YY208		1755	9.7				
03	2.2	Δ200/Y350	IE3	1460	11.2/6.5	2.6	Δ220/Y380-400	IE3	1750	10.6/6.1-5.8	UL(E365362) • CSA IP55 • ISO F • bimetal	29.0	728 [28.7]
							Δ200/Y350		1740	10.8/6.2			
04						2.6	Δ400/Y690	IE3	1760	5.25/3.03	UL(E365362) • CSA IP55 • ISO F • bimetal	37.0	741 [29.2]

• Current consumption and rotation speed may vary. Tolerance in each case -1.5/+2%

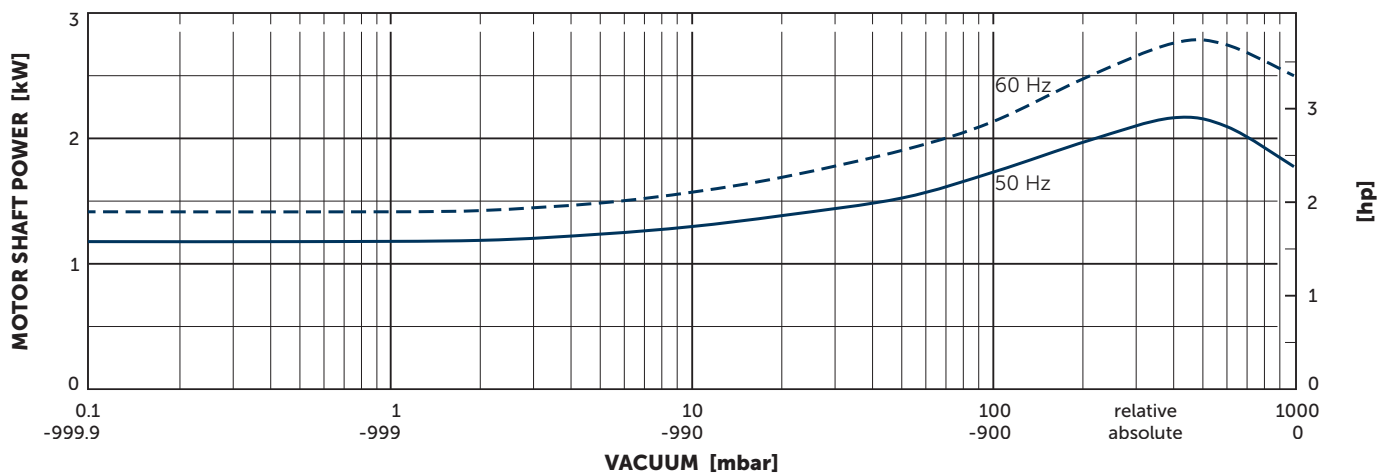
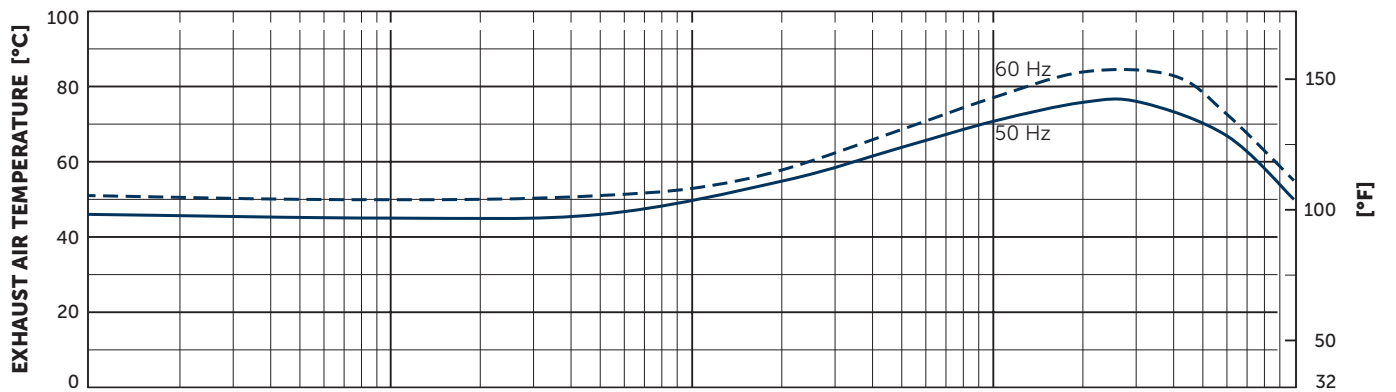
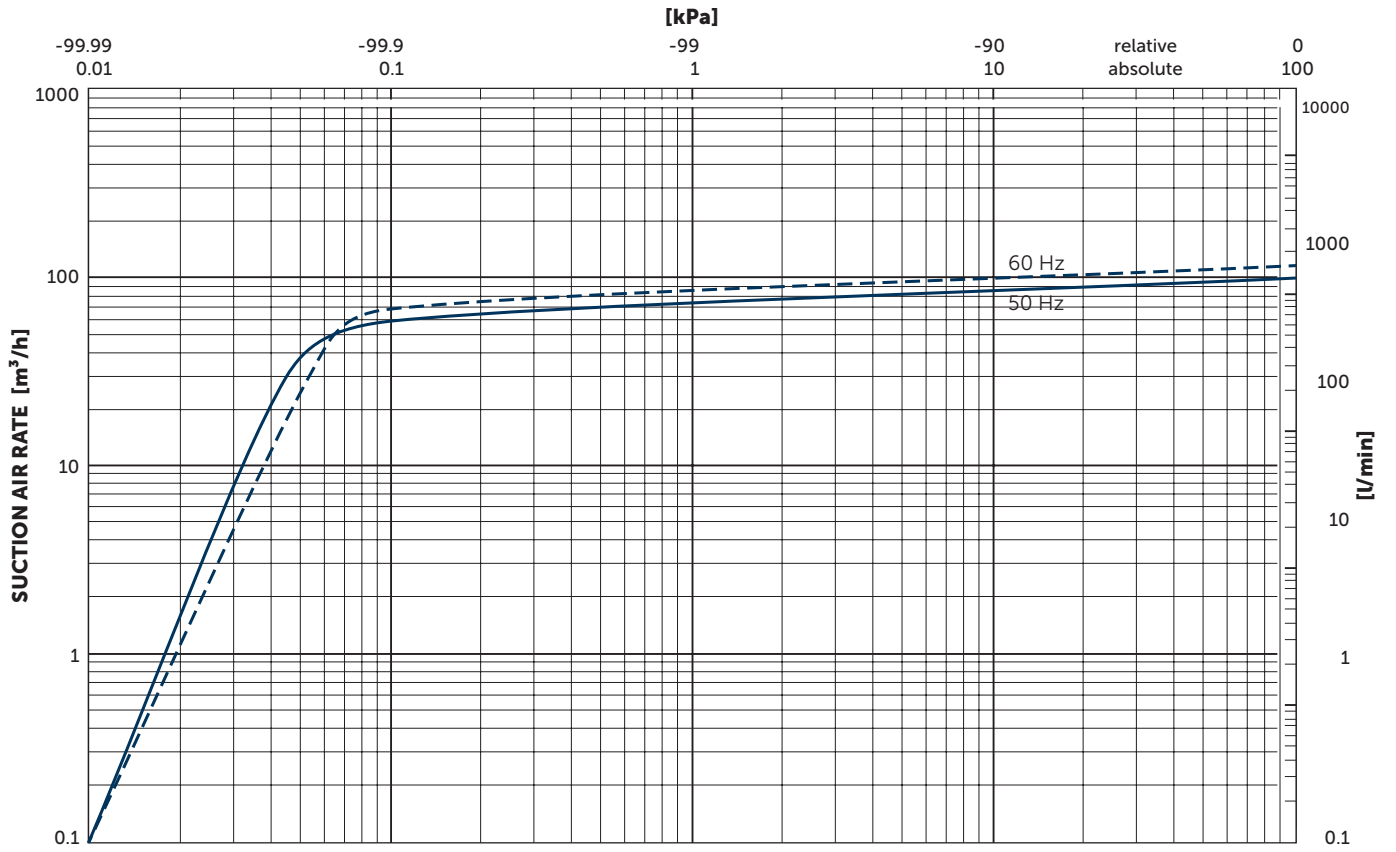

Suction air rate refers to the intake pressure  
 Reference data (atmosphere): 1000 mbar (100 kPa), 20°C (68°F)  
 Tolerance: ±10%

## + VARIANTS AND ACCESSORIES

- Optional **GAS BALLAST VALVE** for increased water vapour tolerance (3.0 mbar absolute)  
water vapour tolerance: max. 62 mbar; water vapour capacity: max. 2.4 l/h (at 85°C operating temperature)
- **THREADED CONNECTOR** for exhaust air (G1<sup>1/4</sup>)
- **U 5.101 O2-PACK**<sup>1)</sup> for packaging with an overconcentration of oxygen
- **VARIAIR U 5.101**<sup>1)</sup> with frequency inverter VAU4/4

### ACCESSORIES

- External suction filter<sup>1)</sup>
- Oil: Becker Lube M100 mineral, S100 synthetic and SL100 food

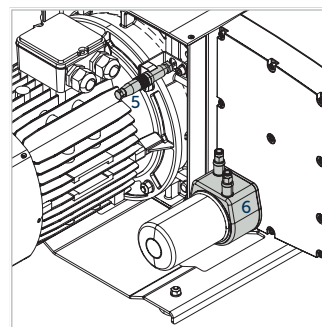
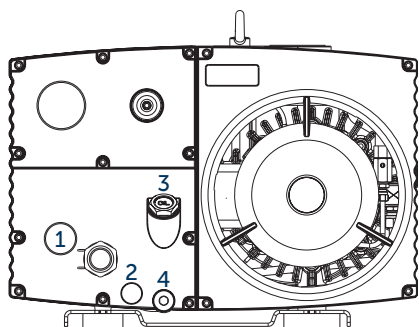

- 1 Oil level switch<sup>1)</sup> (G1)
- 2 Oil temperature monitor<sup>1)</sup> (G<sup>1/2</sup>)
- 3 Maintenance indicator<sup>1)</sup> (G<sup>3/4</sup>) for oil separating elements
- 4 Ball valve (G<sup>1/2</sup>), with locking and hose connector 19 mm
- 5 Temperature sensor PT100
- 6 Water cooler U5.100-0-114.2<sup>1)</sup> with connectors for hoses with an external diameter of 8 mm



Oil level switch



Oil temperature monitor



Maintenance indicator

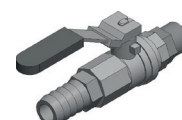

Ball valve

<sup>1)</sup> See separate data sheet

- Combination options on request



**MAKE IT BECKER.**