



TECHNICAL PARAMETERS

Nominal capacity, m ³ /h	63
Ultimate vacuum, mbar abs.	0,5
Water vapour pumping capacity, kg/h	2
Oil capacity, l	2
Rotation speed, rpm	1450
Electric motor characteristics	IM B14 230/400 B ±10%, 50 Hz / IM B14 230 B ±10%, 50 Hz
Motor power, kW	1,5
Sound pressure level, dB(A)	67
Total weight, kg	55

Single-stage rotary vane oil-lubricated vacuum pumps of the **RVL series** are designed for pumping air, vapors and steam-gas mixtures.

The pumps are highly reliable, easy to operate and provide stable vacuum during continuous operation. They are most often used in the food industry, woodworking, vacuum packaging and central vacuum units in medicine. Pumps of this type are used in technological processes of the chemical industry, in the production of composite materials, cable products, as well as backing pumps in hybrid vacuum units with Roots pumps.

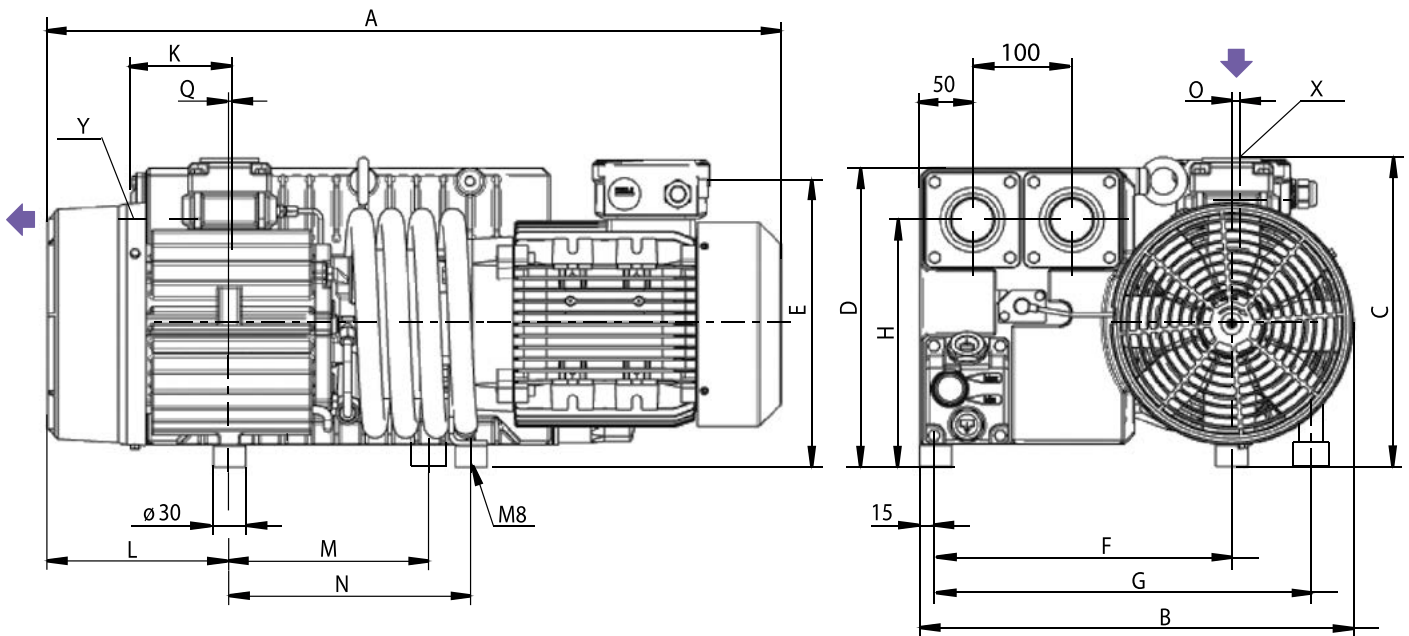

A	B	C	D	E	F	G	H
635	406	289	289	269	277	277	231
K	L	M	N	O	Q	Inlet, X	Outlet, Y
93	137	0	199	0,3	0	G1 ¼"	G1 ¼"

All dimensions in the drawings are indicated in mm

PUMPING CURVE

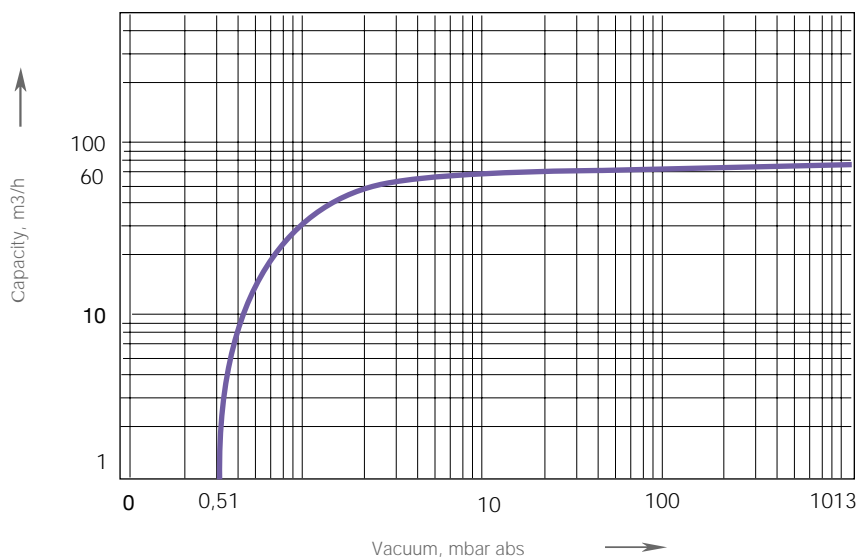

The presented characteristics are valid for dry air at temperatures up to 40 °C and an atmospheric pressure of 1013 mbar abs. Tolerance of the characteristics is ± 10%.

ADVANTAGES OF RVL PUMPS



Compact design

allows easy integration of RVL vacuum pumps into machines



Highly efficient oil separator

ensures that the air coming out of the pump is clean from oil particles and droplets



Working 24/7

the pumps are designed for continuous operation 24 hours a day, 7 days a week



Built-in check valve

protects the pump when multiple pumps are running at the same time. Prevents oil from being carried away when the pump is switched off

VACUUM FILTERS

Air filters are used to protect the internal parts of pumps from dust and solid mechanical particles contained in the environment of the enterprise.

Model	FG 110
Inlet capacity, m³/h	108
Filtration degree, microns	5
Connection	G ¼"

